

Midwest Group One

2645 26th Avenue South

Minneapolis, MN 55406 USA

612.721.5347 voice

612.721.1736 fax

midwestgroupone.com

For more information, contact:

**Bob Benson**

email: [bbenson@midwestgroupone.com](mailto:bbenson@midwestgroupone.com)

tel: 612.721.5347

**Ed Strahota:**

email: [estrahota@midwestgroupone.com](mailto:estrahota@midwestgroupone.com)

tel: 612.843.1325

### Postformed Kitchen Countertop



Photograph "Canyon Creek" Courtesy of WilsonArt®

*For over 50 years, Midwest Automation has designed, manufactured, installed and serviced kitchen countertop postforming and laminating systems around the world.*

Kitchen Countertop Series

**USED Postforming  
& Laminating System**

**MA MIDWEST  
AUTOMATION**

*Innovative Products for Innovative People*

midwest  
GROUP ONE



**Corfab 1521, S/N 21-7609**

Includes new paint, a rebuilt Nordson® hot melt unit, special infeed table, outfeed roller conveyor, and dust collector

(not actual machine)



**SS 2070 Spray System, S/N 165-9304**

Includes panel cleaner, infeed/outfeed roller conveyors, belt conveyor and drying tunnel (not actual machine photograph)



**IX 2105 Index Table, S/N 190-9002**

Includes new paint, infeed roller conveyor, upgraded individual vacuum generators, and new large diameter suction cups



*Actual system photograph excluding the Spray System.*

**Line System**

## **Used Postforming & Laminating System** *with Solvent-Based Adhesive Spray System*

*The system includes a combination of factory-reconditioned, factory-tested, and used machines to provide a complete turn-key system. The system is configured to produce standard postformed kitchen countertop, vanity, and bartop profiles at the rate of approximately one (1) per minute.*



**PR 2150 Pinch Roller, S/N 3217-8001**

Includes new paint and refurbished upper and lower segmented rollers



**MF 118 Miniform Postformer, S/N 166-9006**

Includes new paint, infeed/outfeed roller conveyors, I/R heaters, hot air guns, outfeed trimmers, and slitter saw



**AC 3120 Autocove, S/N 147-8010**

Includes new paint, outfeed roller conveyor, new heat bar assembly, and Nordson® Hot Melt Unit

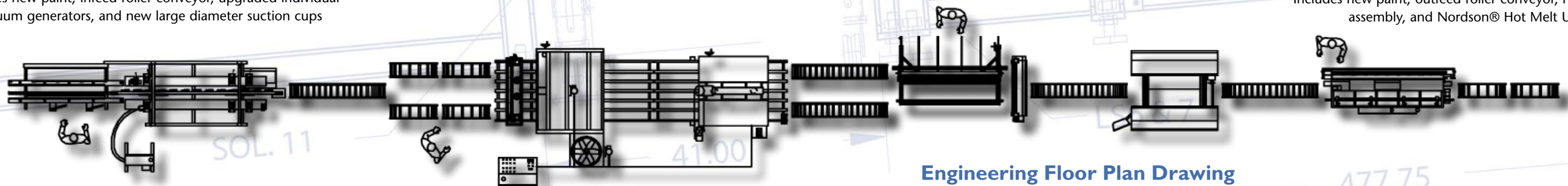

**Engineering Floor Plan Drawing**